









Bodymaker

-  Fully CE compliant guarding allowing convenient access to the machine

 Plug and play service connections aid reduced on-site installation time

 Hydraulic Power Pack ensures oil cleanliness is maintained to ISO standard, reducing oil contamination and risk of breakdown

 Option to incorporate latest CMB Microdome

 Improved hold-down mechanism for cup redraw to improve reliability and accuracy
-  Overbalanced crankshaft to minimise vibration

 Latest electrical systems

 Hydraulic clutch and brake for accurate stopping at high speeds and reduced maintenance

 AutoBAR™

 Latest pneumatic technology

 Machines can be tailored to bespoke Cup requirements

Contact our team to find out more about the CMbE Bodymaker

Call Us +44(0)1274 846200
 Email Us sales@cmbe.com
 Online www.cmbe.com



Technical Data

Stroke:	22"	24.5"	26"	30"
Max. untrimmed can height:	159mm	*189mm	200mm	*244mm
Max. can diameter:	52-73mm (202-300)	52-84mm (202-307)	52-73mm (202-300)	52-73mm (202-300)
Main Motor:	55kW (74hp)			
Air:	<u>Supply</u> 6.2 bar (90psi) min		<u>Consumption</u> 1.8m ³ /min (65cfm)	
Typical Weight: (Dry)	Bodymaker: Control cabinet: Hydraulic powerpack:		10,400Kg (22,930lbs) 526Kg (1160lbs) 960Kg (2120lbs)	
Guards:	Complete safety guarding, electronically interlocked to the control system. Fully conforms to the requirements of the European Machinery Safety Directive			

**Dependent upon Cup geometry*

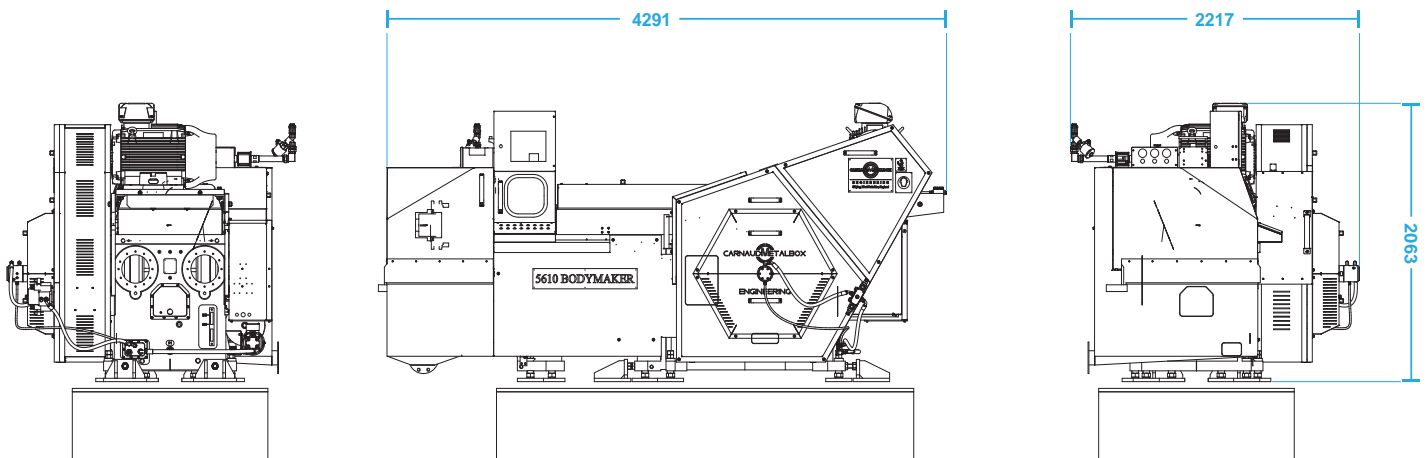

Contact our team to find out more about the CMbE Bodymaker

Call Us +44(0)1274 846200
 Email Us sales@cmbe.com
 Online www.cmbe.com

