















Die Necker

-  Reduced changeover and set up time through advanced machine design
-  Works at speeds of up to 3400 cpm
-  Automatic centralised grease lubrication
-  Reduced maintenance and downtime due to improved machine dynamics
-  12-head, 10-head and 8-head variants available to suit your production output requirements
-  Acoustic Reduction Guarding

Additional process units:

-  Flanging
-  Internal Base Reforming
-  Light Tester
-  Vision Inspection
-  Intermediate Infeed
-  Reverse Can Ejection

Contact our team to find out more about the Die Necker

Call Us +44(0)1274 846200
Email Us sales@cmbe.com
Online www.cmbe.com



Technical Data

Min. trimmed Can height:	88mm
Max. trimmed Can height:	220mm
Can diameters:	53-66mm (202-211) *
Speed:	Up to 3400cpm
Each Main motor:	18.87kW
Each Main vacuum fan:	17.4kW
Waxer vacuum pump:	11kW
Discharge blower:	1.5kW
Vacuum:	8-10In/HG @30ACFM
Air consumption:	Each necking stage - 55SCFM Light Tester - 10SCFM IBR - 30SCFM
Weight:	Each base - 2000kg Intermediate base - 2300kg
Guards:	Complete safety guarding, electronically interlocked to the control system.
Additional Features:	Minimal lubrication requirements. Automatic centralized grease lubrication. Non-metallic gears, eliminating the requirement for oil lubrication. Innovative anti-rotation feature, extended life of Pusher rams. 1.75" pusher stroke, allowing the tooling to incorporate increased tooling length, giving greater can neck-to-body concentricity.

* Alternative can sizes available on request

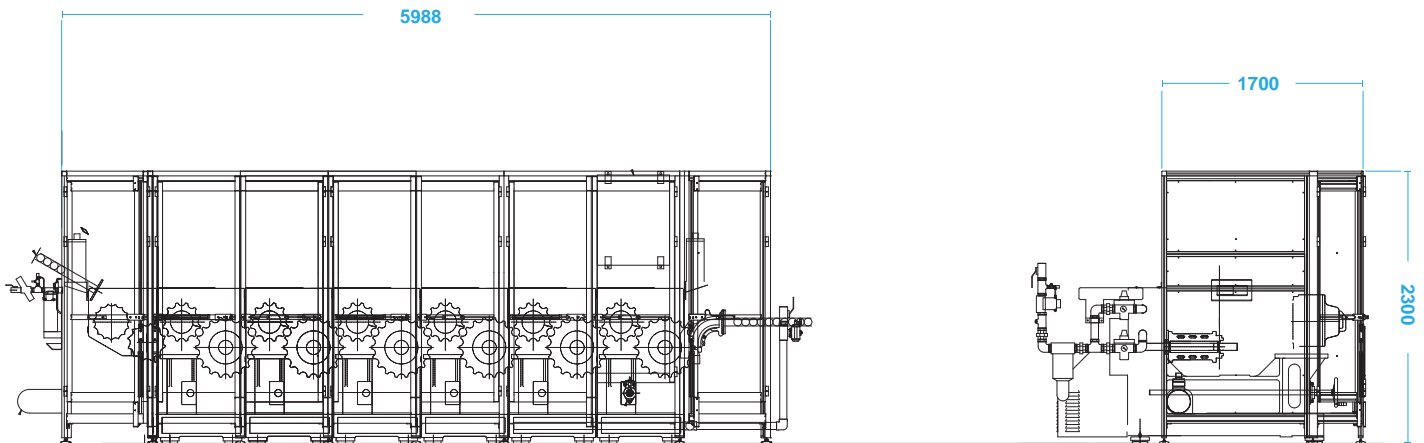

Contact our team to find out more about the Die Necker

Call Us +44(0)1274 846200
Email Us sales@cmbe.com
Online www.cmbe.com