

reformat™ Spray Machine



Reduced energy consumption – consumes 75% less energy than other models



Improvements in process control - able to modulate speed



Reduced footprint



Designed to minimise tool usage



Increased speed – able to reach higher speeds compared to previous mechanical spray machines



Can be run at very low speeds to keep the guns active during impeding line build back or low line infeed level



Reduced down time – quicker to clean



Fully adjustable machine designed for quick height & diameter change overs

Contact our team to find out more about the reformat™ Spray Machine

Call Us +44(0)1274 846200
Email Us sales@cmbe.com
Online www.cmbe.com



Technical Data

Min. trimmed Can height:	88mm
Max. trimmed Can height:	220mm
Min. Can diameter:	202(52mm)
Max. Can diameter:	211(66mm)
Main Motor:	9.3kW
Spinner Motor:	0.37kW
Speed:	Up to 400cpm
Weight:	Approx. 3200kg for 2 machines (inc straddle frame)
Air Supply:	90PSI
Spray:	Nordson Spray Equipment
Drive:	Servo Motor and Gearbox
Guards:	Complete safety guarding, electronically interlocked to the control system
Additional Features:	Mis-spray Detection (Nordson iTrax® Spray Monitor) or Sencon Nordson Spray Pressure Control Nordson Temperature Control (TCU) Unit Nordson iTrax® Spray Controller (Model SC) Nordson iTrax® Pressure Controller (Model PRx)

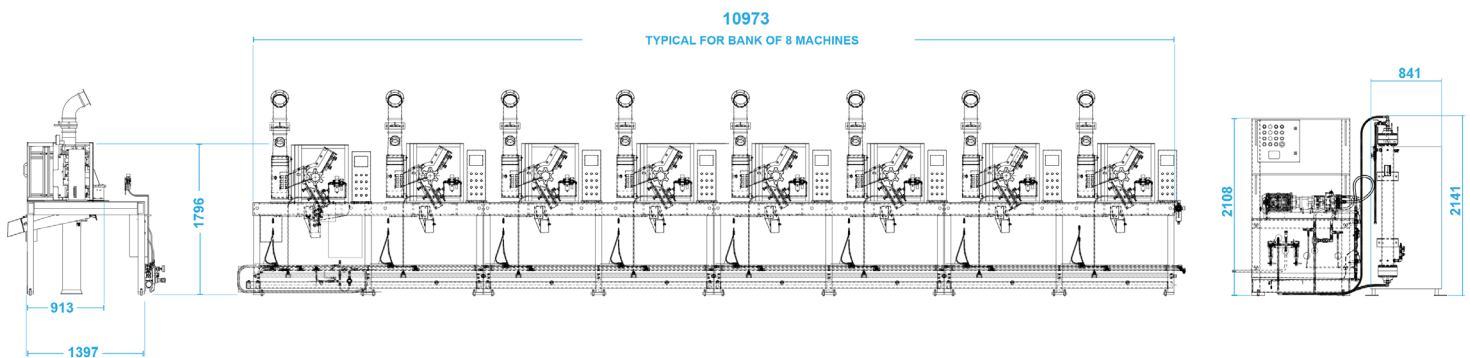

Contact our team to find out more about the reformat™ Spray Machine

Call Us +44(0)1274 846200
Email Us sales@cmbe.com
Online www.cmbe.com

