

Category: Recommended

Due to increased global demand for Ø204 Slek Cans, CarnaudMetalbox Engineering Ltd (CMbE) have successfully collaborated with Parker Hannifin's Engineered Materials Group to create a new Ø56mm Ram Seal. CMbE are advising all customers to use the genuine Parker Ram Seals for all of our Bodymaker Series machines.

CMbE recommend that all customers discontinue the use of the existing ram seals (**Part # MT56X72X8-PU & MT56X72X8-PU1**) and purchase the new and improved Ø56mm Parker Ram Seals (**Part # 23136635**) from CMbE Canline Spares.

By using genuine Ø56mm Parker Ram Seals, customers have benefited from improved Ram stability, improved overall longevity and commonality of seal design across all Ram diameters. All new seals have RA (Revision A) moulded into the seal (**Fig. 1**), as this guarantees the mould has been updated to optimise the interference between the Ram diameter and the seal bore.



Fig. 1

Please be aware that for Hydrostatic Ram housings, if upgrading from the discontinued ram seals (**Part # MT56X72X8-PU & MT56X72X8-PU1**) to the new Parker Ø56mm Ram Seal, the **4051671B** Seal Spacer will need to be replaced with **4202630** (2 per machine). This will maximise seal performance by reducing the axial clearance within the Sealpack. The Ø56mm Parker Ram Seals are orange in colour and assembled in packs of 3 as shown below:



Fig. 2
Ø56mm Parker Ram Seal

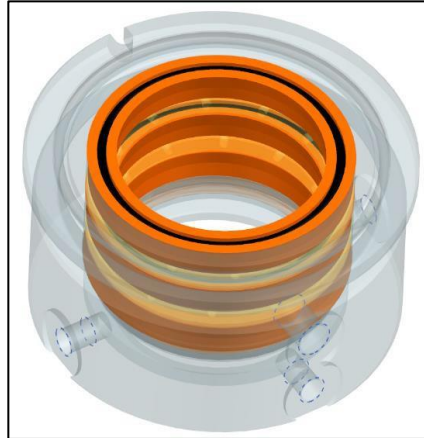

Fig. 3
3 x Ø56mm Parker Hydrostatic Seal Pack
(Installed in situ.)

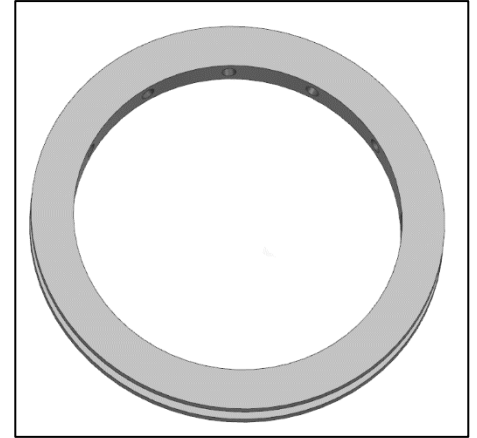

Fig. 4
4202630 Seal Spacer

For further information regarding this Technical Bulletin, please contact either of the references at CarnaudMetalbox Engineering Ltd below, quoting Technical Bulletin reference **TB5000-095**.

A complete library of Technical Bulletins is now available on the company website.

