

CATEGORY: Recommended on all Trimmer units, either stand alone or part of the Canmaker system, to help reduce diameter change over time (up to 2 hours per machine).

Summary: To reduce change over time on the 550 Trimmer when changing can diameter Carnaud Metalbox Engineering recommend implementing additional Discharge Guide Assemblies (Figure 1) for each different can diameter. These additional assemblies can be used with the diameter related guides already fixed in position meaning the whole assembly can be removed and replaced as one unit rather than disassembling guides and brackets individually.

This upgrade is particularly ideal for customers that regularly convert their machinery between slim (202), sleek (204) and 211 body diameter cans.

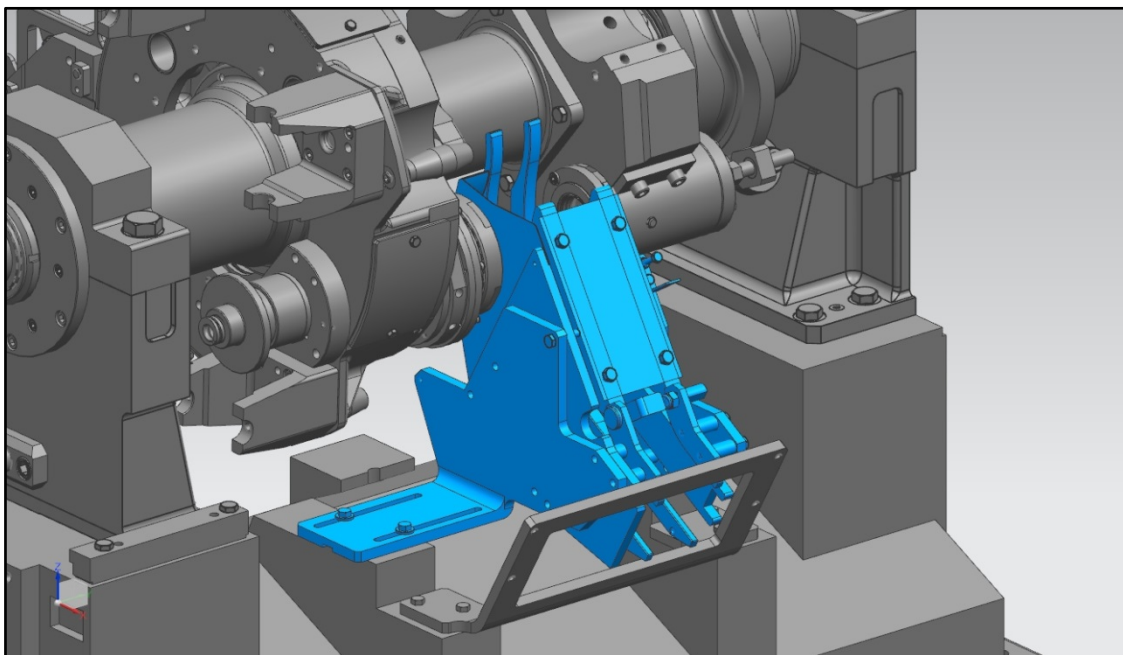

Figure 1 Discharge Guide Assembly (Blue)

NOTE: For further information regarding this Technical Bulletin please contact either of the contacts below quoting Technical Bulletin number **TB550-005** and your machine Serial Number. A complete library of technical bulletins is available on the company web site.

Carnaud Metalbox Engineering Plc,
Dockfield Road, Shipley,
West Yorkshire, BD17 7AY, UK
Tel: +44 1274 846200, Fax: +44 1274 846201
e-mail: sales@CMBEcanmaking.com

Carnaud Metalbox Engineering Plc,
79 Rockland Road, Norwalk,
Connecticut 06854, USA
Tel: +1 203 853 7325, Fax: +1 203 866 7627
e-mail: sales@CMBEcanmaking.com